



# TC755LL

LEVERLESS TYRE CHANGER



# TC755LL

## LEVERLESS TYRE CHANGER

41 mm hexagonal vertical arm to reduce flexures in case of Run-flat tyres

The horizontal arm is locked by a cylinder. The roller at the base of the arm guarantees optimal sliding, and being blocked by an eccentric bush it can be used to minimize any play generated by usage



Leverless group

Device to minimize tolerances on vertical shaft

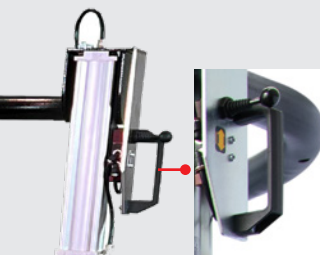

New helper group handle: practical, fast and ergonomic

Wheel bead breaking group with innovative approach to the rim

Centre post with adjustable height

Pedal for tyre inflating on the turntable centre post

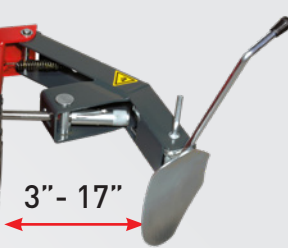

3" - 17"

Blade system for conventional tyres

Four pedals aligned in the front. Removable pedal unit

Inverter motor with proportional speed (0-16 rpm)

### TECHNICAL DATA

410 kg	10" - 30" 265 ÷ 765 mm	3" ÷ 16" 75 ÷ 405 mm	46" 1160 mm	All tyres	1200 kg	1500 kg / 2850 kg at cylinder	Standard			8 - 12
							MI 230V/1/50-60 Hz	0 - 16 rpm	1,5	
							On request			
							MI 110V/1/60 Hz	10 / 17 rpm	1,5	
							400V/3 - 2V	7 / 14 rpm	0,9 - 1,1	
230/3 - 2V	7 / 14 rpm	0,9 - 1,1								

# ERGONOMIC AND INTUITIVE CONTROLS

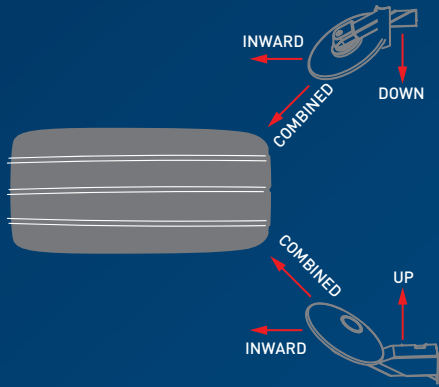

TC755LL controls allow to operate the upper and lower rollers with only one switch each, managing all movements:

- Up and down
- Forward and backward
- Combined

**LL demounting group (Leverless - M&B patent):** system with double support to the rim to reduce flexions and tensions on the bead and on the rim edge. It strongly reduces the physical effort by the operator. Quick and safe **wheel locking** with adjustable height centre post system and new rubber surface to allow the clamping of "reverse" rims even directly on the plate itself.

**Proportional inverter motor** with 0-16 rpm rotation speed. Proportional operation allows stepless speed change.

**Vertical arm with increased thickness of 41 mm** to ensure greater rigidity even with particularly "hard" wheels and equipped with a mechanism that reduces any bending even after prolonged use.

**The horizontal arm is locked by means of a cylinder.** The roller at the base of the horizontal arm ensures optimal sliding, and since it is blocked by an eccentric it can be used to reduce the clearance that can be generated with use.

**Horizontal arm, 2" higher,** allows working on wheels up to a maximum width of 16". A new fastening system facilitates its perfect sliding.

**Bead breaker with enhanced force** thanks to increased rod and cylinder diameters.

**Helper group (optional)** for mounting UHP and Run Flat tyres with new handle more practical, fast and ergonomic.

**Gruppo di smontaggio LL (Leverless - M&B patent):** sistema con doppio appoggio al cerchio per ridurre le flessioni e le tensioni sul tallone e sul bordo cerchio. Riduce al minimo lo sforzo fisico da parte dell'operatore.

**Bloccaggio ruota** rapido e sicuro con sistema a platello e nuovo piano di appoggio in gomma per consentire il serraggio di cerchi "reverse" anche direttamente sul piattello stesso.

**Motore inverter proporzionale** con velocità di rotazione 0-16 rpm. Il funzionamento proporzionale permette di cambiare velocità in modo continuo.

**Braccio verticale con spessore maggiorato di 41 mm** per garantire maggiore rigidità anche con ruote particolarmente "dure" e dotato di un meccanismo che riduce eventuali flessioni anche a seguito di un utilizzo prolungato.

**Bloccaggio del braccio orizzontale tramite un cilindretto.** Il rullino alla base del braccio orizzontale garantisce uno scorrimento ottimale ed, essendo bloccato da un eccentrico, può essere utilizzato per ridurre i giochi che si possono generare con l'uso.

**Braccio orizzontale, più alto di 2",** permette di lavorare su ruote fino ad una larghezza massima di 16". Un nuovo sistema di fissaggio ne agevola il suo perfetto scorrimento.

**Paletta stallonatrice con forza potenziata** grazie ai diametri maggiorati di stelo e cilindro.

**Helper group (opzionale)** per il montaggio di ruote UHP e Run Flat con nuova maniglia più pratica, veloce ed ergonomica.

**Groupe de démontage LL (Leverless - M&B patent):** système avec double appui sur la jante afin de réduire la flexion et la tension sur le talon et sur le bord de la jante. Réduit au minimum l'effort physique par l'opérateur.

**Blocage rapide et sûr de la roue** avec système de plateau et nouveau plan d'appui en caoutchouc pour permettre le serrage de jantes « renversées » même directement sur le plateau.

**Moteur inverseur proportionnel** avec vitesse de rotation 0-16 tr/min. Le fonctionnement proportionnel permet de changer de vitesse en continu.

**Bras vertical avec une épaisseur accrue de 41 mm** pour garantir une plus grande rigidité même avec des roues particulièrement « dures » et équipé d'un mécanisme qui réduit les flexions possibles même après une utilisation prolongée.

**Blocage du bras horizontal s'effectue par l'intermédiaire d'un cylindre.** Le rouleau à la base du bras horizontal garantit un glissement optimal, et étant bloqué par un excentrique, il peut être utilisé pour réduire les jeux qui peuvent être générés avec l'utilisation.

**Le bras horizontal, plus haut que 2",** permet de travailler sur des roues jusqu'à une largeur maximale de 16". Un nouveau système de fixation facilite son glissement parfait.

**Palette de détalonnage avec une force améliorée** grâce aux diamètres accrus de tige et cylindre.

**Helper group** pour le montage des roues UHP et Run Flat (sur demande) avec nouvelle poignée plus pratique, rapide et ergonomique.

**Demontagekopf LL (Leverless - M&B patent):** System mit doppelter Auflage an der Felge, um Beugungen und Spannungen am Wulst und am Felgenreand zu vermeiden. Reduziert den Kraftaufwand des Bedieners auf ein Minimum.

**Schnelles und sicheres Radaufspannen** mittels Spanntellersystem und neuer gummibeschichteter Aufnahmeblätter, mit dem sich auch Tiefbettfelgen direkt aufspannen lassen.

Stufenlos regelbare Drehgeschwindigkeit von 0-16 U/min dank **proportional gesteuertem Invertermotor.**

**Um 41 mm verstärkte Montagesäule** für mehr Stabilität bei der Bearbeitung auch besonders "harter" Reifen mit Anti-Flex-Mechanismus für erhöhte Biegesteifigkeit auch bei längerem Gebrauch.

**Feststellen des Schwenkarms mittels Druckluftzylinder.** Die Rolle am Ende des Schwenkarms gewährleistet eine optimale Führung und kann dank Exzenter-Verspannung auch zur Reduzierung möglicher Verschleißspiele genutzt werden.

**Der um 2" cm höhere Horizontalarm** ermöglicht die Bearbeitung von Reifen mit einer maximalen Breite von 16". Neuartiges Befestigungssystem zur Gewährleistung einer optimalen Nachführung.

**Abdrückschaufel mit erhöhter Abdruckkraft** dank vergrößerter Kolbenstangen- und Zylinderdurchmesser.

**Hilfsarm (auf Anfrage)** für die Montage von UHP- und Runflatreifen mit Neuer Griff praktisch, schnell und ergonomisch.

**Grupo de desmontaje LL (Leverless - M&B patent):** sistema con doble apoyo en la llanta para reducir las flexiones y las tensiones en el talón y en el borde de la llanta. Reduce al mínimo el esfuerzo físico por parte del operador.

**Bloqueo rápido y seguro de la rueda** con el nuevo platillo y la nueva protección de apoyo de goma para permitir la sujeción de llantas "reversas" directamente en el platillo.

**Motor inverter proporcional** con velocidad de rotación 0-16 rpm. El funcionamiento proporcional permite un cambio de velocidad continuo.

**Brazo vertical con un espesor adicional de 41 mm** para garantizar una mayor rigidez incluso con ruedas especialmente "duras" y equipado con un mecanismo que reduce posibles flexiones incluso tras un uso prolongado.

**El brazo horizontal se bloquea mediante un cilindro.** El rodillo situado en la base del brazo horizontal garantiza un deslizamiento óptimo, y al estar bloqueado por una excéntrica puede utilizarse para reducir el juego que puede generarse con el uso.

**Brazo horizontal, más alto de 2",** permite trabajar en ruedas de hasta una anchura máxima de 16". Un nuevo sistema de fijación facilita su deslizamiento óptimo.

**Paletilla destalonadora con fuerza potenciada** gracias a los aumentos de diámetro del vástago y del cilindro.

**Grupo de ayuda (opcional)** para montaje de ruedas UHP y Run Flat con nuevo mango más práctico, rápido y ergonómico.

# STANDARD CONFIGURATION



# OPTIONAL ACCESSORIES

					
Helper arm	Extendable bead-pusher with pulling system	Light truck cone	Light truck spacer	Centre closed and reversed rim flange kit	Mounting clamp RFT/UHP
					
Protection for self centering device	Mounting head protection (tail side)	Mounting head protection (front)	Rim white protector	Bead breaker blade nylon protection	Bead seater kit
					
Special adaptor for light trucks and rims with protruding spokes	Wheel lift	Wheel bead breaking roller	Light and 230/1/50-60 power supply kit (factory assembled)		

# OVERALL DIMENSIONS

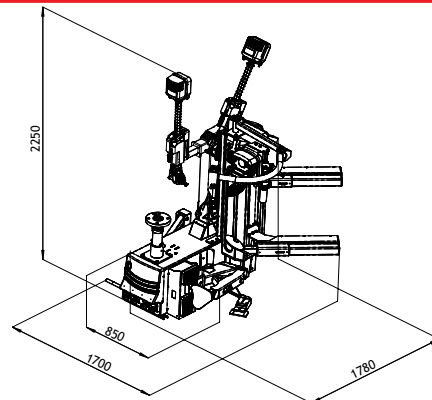
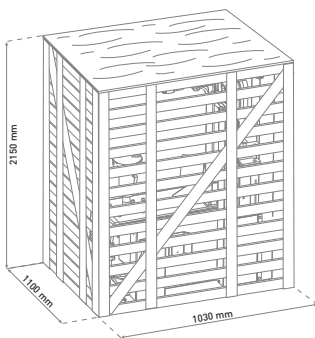

M&B ENGINEERING SRL  
Via Nobel, 21 - 42124 Reggio Emilia (RE)  
info@mb-re.it - www.mbenengineering.info